



TECHNICAL BULLETIN

No: LTB00034
Issue: 2
Date: 20 MAY 2010

CIRCULATE TO:

SERVICE ✓

PARTS ✓

WARRANTY ✓

BODY SHOP ✓

ISSUE '2' CHANGES ARE LIMITED TO INSTRUCTING TECHNICIANS TO CARRY OUT THIS REPAIR PROCEDURE IN CONJUNCTION WITH TECHNICAL BULLETIN LTB00218.

SECTION: 501

Passenger Compartment Water Ingress

AFFECTED VEHICLE RANGE:

Range Rover Sport (LS)

VIN: 6A900129 - Onwards
Model Year: 2006 - Onwards

CONDITION SUMMARY:

POSSIBLE CAUSES AND RESOLUTION OF WATER INGRESS

This bulletin provides technicians with guidance for identification of possible water ingress causes when water enters the passenger compartment. If a customer complains of water ingress, locate the point of origin and take the appropriate corrective action.

Symptom	Potential Root Cause
Water Ingress through headliner in proximity of roof opening panel.	Sealed end valve of the roof opening panel drain tubes. This may affect any one of the four roof opening panel drain tubes on the vehicle.
	Poorly routed, kinked or twisted roof opening panel drain tubes.
	Roof opening panel alignment.
Water ingress through headliner in proximity of roof opening panel, predominantly front right-hand side of roof opening panel although depending upon inclination of vehicle or acceleration/deceleration, ingress may be evident at other points around the roof opening panel.	Foam sound-deadening pad in right-hand side fender air intake blocking the sunroof panel drain tube.
Water ingress to foot well or lower D-pillar area.	Roof opening panel drain tube end not routed through the fender or wheel arch; drain tube end pinched or clogged with debris.
Water ingress to passenger side foot well; water dripping from the glove compartment area. Note: There may be a delay of days between the vehicle being subjected to water and the complaint of water ingress arising due to the time taken for the water to soak through the pollen filter.	Plenum chamber panel not securely clipped, allowing water to pass through the air inlet, positioned on the passenger side of the vehicle, and collecting in the pollen filter.
Illumination of miscellaneous warning lamps and/or water in foot well.	Refer to Technical Bulletin LS501-007.

NOTE: The information in Technical Bulletins is intended for use by trained, professional Technicians with the knowledge, tools, and equipment required to do the job properly and safely. It informs these Technicians of conditions that may occur on some vehicles, or provides information that could assist in proper vehicle service. The procedures should not be performed by 'do-it-yourselfers'. If you are not a Retailer, do not assume that a condition described affects your vehicle. Contact an authorized Land Rover service facility to determine whether this bulletin applies to a specific vehicle.



PARTS:



NOTE: A customer may report water ingress during the use of a high pressure car wash. If the vehicle was built prior to VIN 6A922812 the roof opening glass panel assembly bracket may prevent sufficient travel to meet alignment specifications. Follow the troubleshooting and diagnosis Repair Procedures detailed in this bulletin to determine cause of water ingress and verify if the glass panel requires replacement. Glass panel may only be replaced when it is determined to be the root cause of the leak.

EFT500032Roof opening glass panel assembly Qty: 1 (if necessary)

WARRANTY:

This procedure is issued for information and guidance only. Only those procedures justified by a customer complaint are allowed to be claimed, and will be subject to warranty audit.

Normal warranty policy and procedures apply.

REPAIR PROCEDURE

TEST SUNROOF DRAINS



NOTE: If the drain tube has come apart, refer to Technical Bulletin LTB00218, *Water Leak Into Footwell From Roof Opening Panel Drain Tube*, for further repair information.

1. Perform the following test to determine if the sunroof drain tubes are functioning normally or are potentially the water ingress source.



NOTE: The restricted access caused by the roof opening panel glass may require the vehicle to be inclined rearward slightly to pass water down the rear drain holes. To prevent mis-diagnosis, the rear drain tubes require a greater volume of water poured into the water trap than when testing the front drains due to the rear drains venting into the rear bumper area.

- Place the vehicle on dry level ground.
- Fully open the sunroof panel to gain access to the water trap.
- Carefully pour water into the water traps, one corner at a time so that the water drains into the drain hole and drain hose. (Figures 1 and 2)
- Confirm that water has pooled on the ground at all four drain points under the A-pillar and D-pillar on both sides of the vehicle. (Figures 1 and 2)

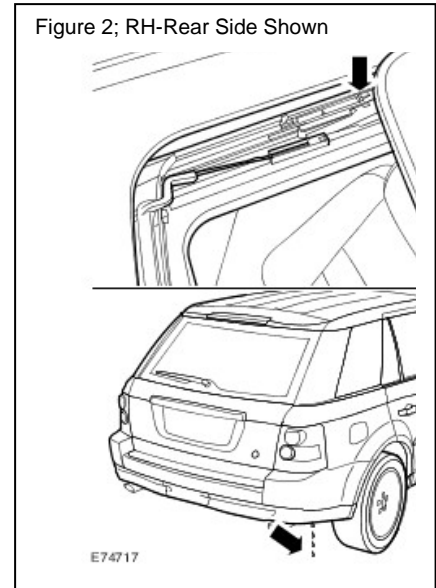
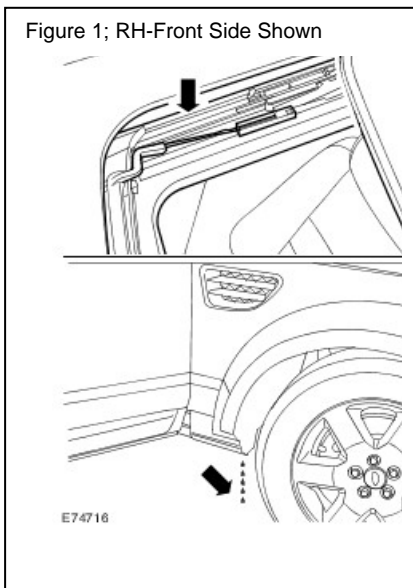

RIGHT FRONT DRAIN CORRECTION PROCEDURE

NOTE: This procedure should be followed if there is no water found pooling on the ground below the RH-side A-pillar during testing.

CAUTION: Care should be taken when removing the fender air intake grill to prevent damage to retaining clips.

1. Remove the fender air intake grill by first pulling up to release the two lower clips and then pulling down and outward to release the two upper clips. (Figure 3)
2. Move the air duct aside. (Figure 4)
3. Release the foam insulation pad to gain access to the roof opening panel drain tube end. (Figure 4)
4. Verify that the drain tube is protruding through the hole in the body. (Figure 5)

NOTE: GTR lookup sequence is as follows:
GTR Home > NAS > LS - Range Rover Sport > Service Information > Model Year > Workshop Manuals

5. If the tube is not protruding through the hole in the body perform the following steps to correctly position the roof opening panel drain tube:
 - Refer to Workshop Manual (GTR) Section 501-05, *Interior Trim and Ornamentation (76.13.27)*, and remove the cowl side trim panel to gain access to the roof opening panel drain tube.
 - Connect and secure the drain tube through the hole.
 - Verify the valve of the roof opening panel drain tube can be fully opened. (Figure 6)
 - If the valve can not be opened, cut as required to permit full opening. (Figure 6)
 - Install cowl side trim panel

Figure 3; RH Front Shown

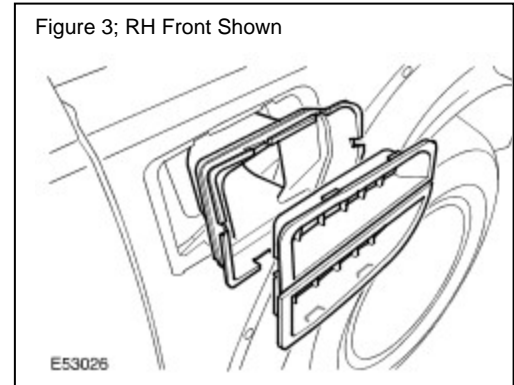

Figure 4; RH Front Shown

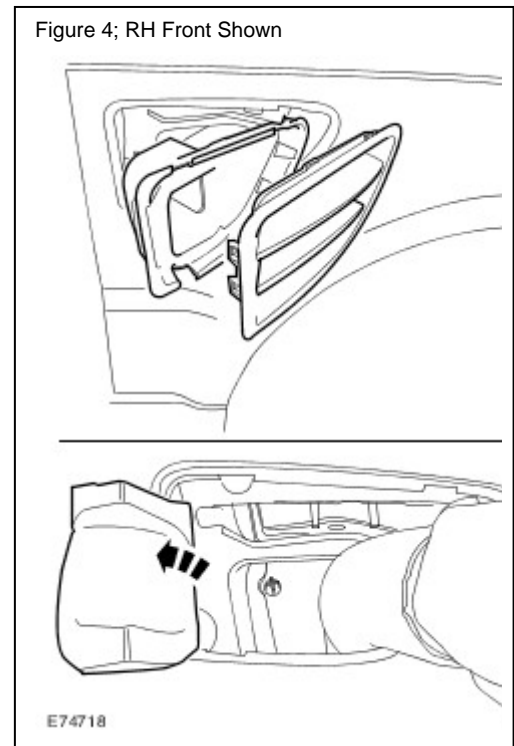

Figure 6

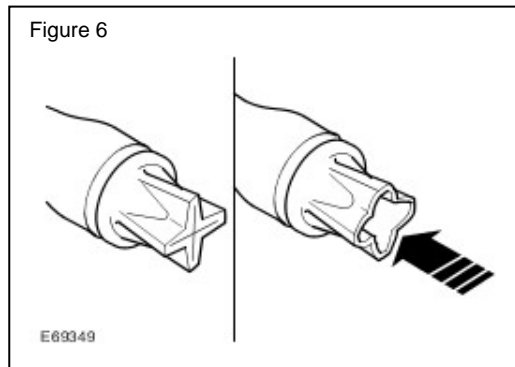
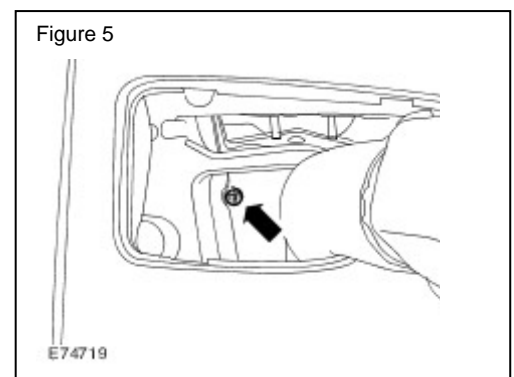
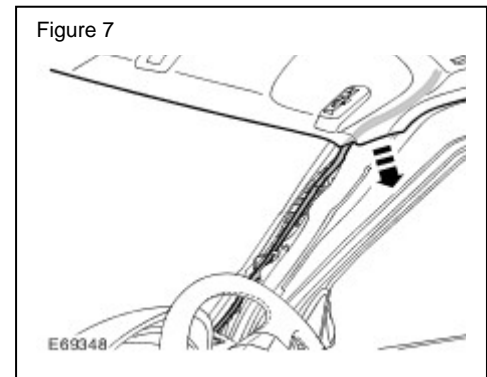

Figure 5



NOTE: If both the routing of the roof opening panel drain tube is correct and the valve of the roof opening panel drain tube cannot be faulted, the foam insulation pad may be the cause. The foam sound-deadening pad may have been installed in such a way as to block the roof opening panel drain tube end.

6. Remove and then install the foam sound-deadening pad, taking care to ensure that the roof opening panel drain tube valve locates in the indent in the foam insulation pad to avoid crimping the tube.
7. Confirm free-flow of water by repeating the **TEST SUNROOF DRAINS** procedure for the right front drain.
8. If satisfactory test is completed install the duct and fender air intake grill.
9. If satisfactory test is NOT completed, blow out the drain tube with compressed air and test again.
10. If satisfactory test is still NOT completed, refer to Workshop Manual (GTR) Section 501-05, *Interior Trim and Ornamentation* (76.13.27), and remove the headliner to gain access to the drain tube. (Figure 7)
11. Inspect for misrouting or kinking of the roof opening panel drain tube paying particular attention to :
 - Collapsed elbow joints
 - Pinched tube
 - Inclined routing
12. Repair drain tube routing as necessary and confirm free-flow of water by repeating the **TEST SUNROOF DRAINS** procedure.
13. If satisfactory test is completed, install the headliner.
14. Install fender foam sound deadening pad, taking care not to block or crimp the drain tube end.
15. Position air duct and install fender air intake grill.



LEFT FRONT DRAIN CORRECTION PROCEDURE

NOTE: This procedure should be followed if there is no water found pooling on the ground below the left-hand side A-pillar during testing. There is no air ducting or foam insulation behind the left-hand side air intake grill.

CAUTION: Care should be taken when removing the fender air intake grill to prevent damage to retaining clips.

1. Remove the fender air intake grill by first pulling up to release the two lower clips, then pulling outward to release the two upper clips to gain access to the roof opening panel drain tube end. (Figure 3)
2. Verify that the drain tube is protruding through the hole in the body. (Figure 5)

NOTE: GTR lookup sequence is as follows:
GTR Home > NAS > LS - Range Rover Sport > Service Information > Model Year > Workshop Manuals

3. If the drain tube is not protruding through the hole in the body perform the following:
 - Refer to Workshop Manual (GTR) Section 418-00, *Module Communications Network* (86.70.56), and remove the CJB to gain access to the roof opening panel drain tube.
 - Connect and secure the drain tube through the hole in the body.
 - Check the valve of the roof opening panel drain tube can be fully opened. (Figure 6)
 - If the valve can not be opened, cut as required to permit full opening. (Figure 6)

4. Confirm free-flow of water by repeating the **TEST SUNROOF DRAINS** procedure for the left front drain.
5. If the concern has not been corrected, blow out drain tube with compressed air and retest.
6. If the concern has still NOT been corrected, refer to Workshop Manual (GTR) Section 501-05, *Interior Trim and Ornamentation* (76.64.15), and remove the headliner to gain access to the drain tube. (Figure 8)
7. Inspect for misrouting or kinking of the roof opening panel drain tube, paying particular attention to:
 - Collapsed elbow joints
 - Pinched tube
 - Inclined routing
8. Repair drain tube routing as necessary and retest.
9. If satisfactory test is completed install the headliner.
10. Install the CJB and the fender air intake grill.

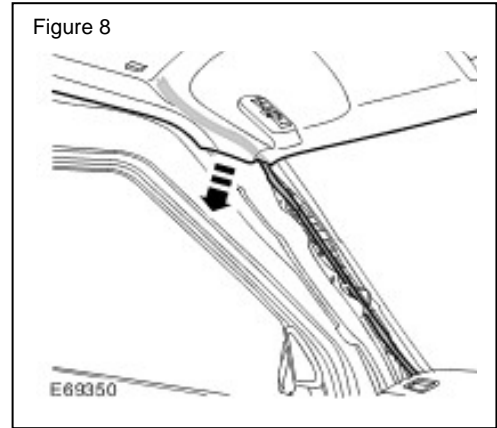

RIGHT REAR DRAIN CORRECTION PROCEDURE

NOTE: This procedure should be followed if there is no water is found pooling on the ground below the right-hand side D-pillar during testing.

1. Open the right-hand side access flap in the tailgate load space to gain access to the roof opening panel drain tube. (Figure 9)
2. Verify that the roof opening panel drain tube is protruding through the hole in the body.

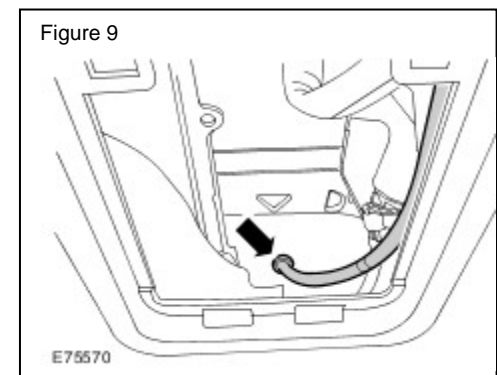

NOTE: GTR lookup sequence is as follows:
GTR Home > NAS > LS - Range Rover Sport > Service Information > Model Year > Workshop Manuals

3. If the tube is not protruding perform the following:
 - Refer to Workshop Manual (GTR) Section 501-05, *Interior Trim and Ornamentation* (76.13.27), and release the right-hand side rear quarter trim panel to gain access to the roof opening panel drain tube.
 - Connect and secure the drain tube through the hole in the body.
4. Check that the valve of the drain tube can be fully opened. (Figure 5)
5. If the valve can not be opened, cut as required to permit full opening. (Figure 5)
6. Confirm free-flow of water by repeating 'Test Sunroof Drains' procedure for the right rear drain.
7. If the concern has not been corrected, blow out drain tube with compressed air and retest.
8. If the concern has still NOT been corrected refer to Workshop Manual (GTR) Section 501-05, *Interior Trim and Ornamentation* (76.64.15), and remove the headliner to gain access to the drain tube. (Figure 10)

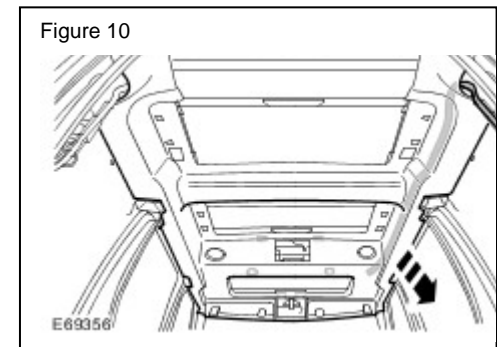

9. Inspect for misrouting or kinking of the roof opening panel drain tube, paying particular attention to:
 - Collapsed elbow joints
 - Pinched tube
 - Inclined routing
10. Repair drain tube routing as necessary and retest.
11. If satisfactory test is completed, install the headliner.
12. Install the right-hand side rear quarter trim panel.

LEFT REAR DRAIN CORRECTION PROCEDURE



NOTE: This procedure should be followed if there is no water found pooling on the ground below the left-hand side D-pillar during testing.

1. Refer to Workshop Manual (GTR) Section 501-05, *Interior Trim and Ornamentation* (76.13.12), and release the left-hand side rear quarter trim panel to gain access to the roof opening panel drain tube.
2. Verify that the drain tube is protruding through the hole in the body.
3. If the tube is not protruding, connect and secure the drain tube through the hole in the body.
4. Check that the valve of the drain tube can be fully opened. (Figure 5)
5. If the valve can not be opened, cut as required to permit full opening. (Figure 5)
6. Confirm free-flow of water by repeating the **TEST SUNROOF DRAINS** procedure for the left rear drain.
7. If the concern has not been corrected, blow out drain tube with compressed air and retest.
8. If the concern has still NOT been corrected refer to Workshop Manual (GTR) Section 501-05, *Interior Trim and Ornamentation* (76.64.15), and remove the headliner to gain access to the drain tube. (Figure 11)
9. Inspect for misrouting or kinking of the roof opening panel drain tube, paying particular attention to:
 - Collapsed elbow joints
 - Pinched tube
 - Inclined routing
10. Repair drain tube routing as necessary and retest.
11. If satisfactory test completed, install the headliner.
12. Install the left-hand side rear quarter trim panel.

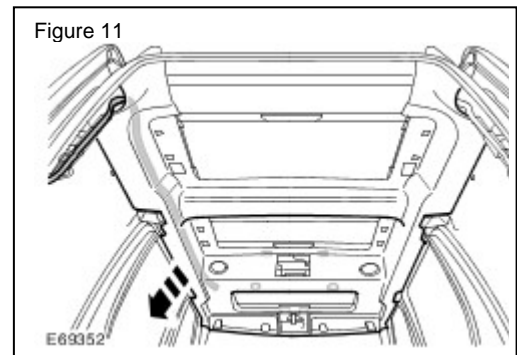

ROOF OPENING PANEL ALIGNMENT AS POTENTIAL LEAK SOURCE



NOTE: When all of the drain tubes are confirmed as functioning correctly the roof opening panel glass alignment can be tested as a leak source.

1. Open the roof opening panel blind, leaving the roof opening panel closed.
2. Verify that the glass panel is centered in its opening.
3. Verify that the front edge is set flush or up to 1.0 mm (0.040 in) below the roof line.
4. Verify that the rear edge is set flush or up to 1.0 mm (0.040 in) higher than the roof line.
5. From inside the vehicle, remove the roof opening panel mechanism covers. (Figure 12)

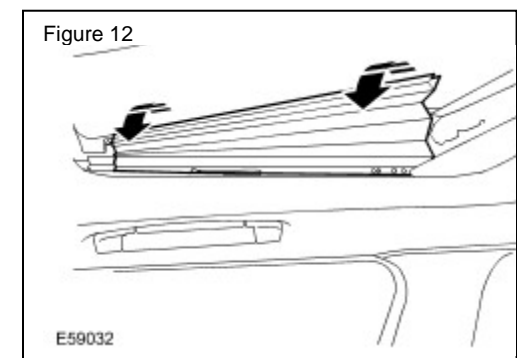



6. Verify that all four (4) Torx screws securing the roof opening panel are correctly positioned and tightened to **6 Nm (4.5 lbf-ft)**. (Figure 13)
7. If the roof opening panel is not set within the specified conditions or if any Torx screw is loose, align the roof opening panel as follows:
 - Loosen the four (4) roof opening panel Torx screws
 - Align the roof opening panel so it is centered in all directions to the exterior roof panel opening
 - Verify that the exterior front and rear edges are set within the specified conditions
 - Tighten the four (4) roof opening panel Torx screws
8. Install roof opening panel mechanism covers.
9. Verify proper operation of the roof opening panel.
10. Close the roof opening panel blind.

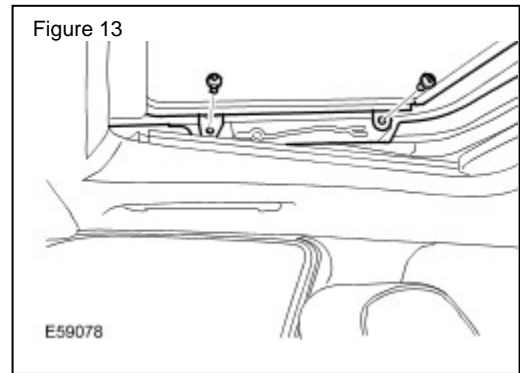

ROOF OPENING PANEL REPLACEMENT

NOTE: If a customer reports water ingress during the use of a machine car wash and the vehicle was built prior to VIN 6A922812 the glass panel assembly bracket may prevent insufficient travel to meet alignment specifications, and the roof opening panel glass assembly may require replacement.

NOTE: GTR lookup sequence is as follows:
GTR Home > NAS > LS - Range Rover Sport > Service Information > Model Year > Workshop Manual

NOTE: The glass panel assembly production date is determined from the 'Day_Month_Year' indicated by the arrows in each of the three dials as illustrated in Figure 14.
Example: the arrows depicted in Figure 14 indicate '18_7_05' - a production date of '18-July-2005'.

1. Verify the glass panel assembly production date indicated by each of the three arrows located on the assembly. (Figure 14)
2. If the production date indicated by the dials is prior to '1_10_05' (01-Oct-2005), refer to Workshop Manual (GTR) Section 501-05, *Interior Trim and Ornamentation* (76.84.03), and replace the roof opening panel glass with part number **EFT500032**.

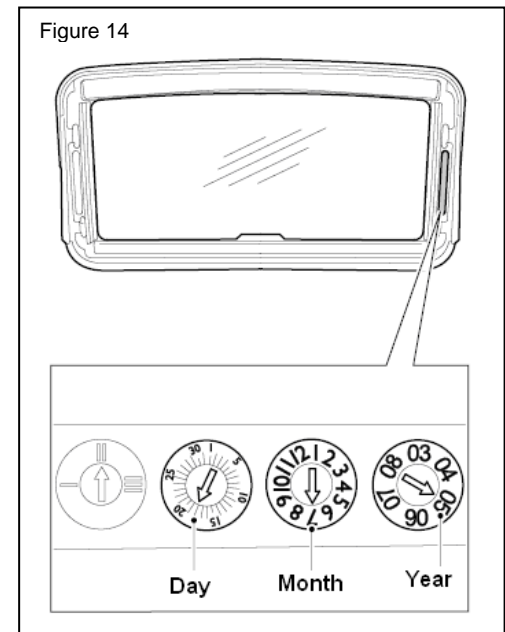



WATER INGRESS TO GLOVE COMPARTMENT OR PASSENGER FOOT WELL



NOTE: If the previous steps have been carried out and both the roof opening panel drain tubes and the alignment / fasteners of the roof opening panel are correctly assembled, without the need for corrective action, this final check may reveal a footwell leak source.

1. Confirm that the plenum chamber panel is securely clipped as follows:
 - Inspect and verify that there is no visible gapping.
 - Gently but firmly applying pressure across the panel to confirm it is seated.
 - Listen for a click sound, which indicates that a clip has engaged (if not already engaged).

A-PILLAR / DRAIN TUBE WATER LEAK INTO FOOT WELL

1. If a customer reports illumination of miscellaneous warning lamps or water in the footwell area, refer to Technical Bulletins LS501-007, *A-Pillar Water Leak*, and LTB00218, *Water Leak Into Footwell From Roof Opening Panel Drain Tube*, for further repair information.