

Rear Stabilizer Bar

Removal



CAUTION: It is possible to install the stabilizer bar incorrectly. Note the position of the stabilizer bar before removal.



CAUTION: Dynamic Response system components are manufactured to very precise tolerances. It is therefore essential that absolute cleanliness is observed when working with these components. Always install blanking plugs to any open orifices or lines. Failure to follow this instruction may result in foreign matter ingress to the Dynamic Response system.

1



WARNING: Do not work on or under a vehicle supported only by a jack. Always support the vehicle on safety stands.

Raise and support the vehicle.

2 . Remove the rear bumper cover.

For additional information, refer to [Rear Bumper Cover \(76.22.74\)](#)

3 . Remove the spare wheel and tire.

4 . Raise the vehicle.

5 . Remove the rear wheels and tires.

6



CAUTION: Before disconnecting or removing the components, ensure the area around the joint faces and connections are clean. Plug open connections to prevent contamination.



CAUTION: Make sure the actuator fluid lines are not damaged or kinked during removal or installation.

NOTE:

Some fluid spillage is inevitable during this operation.

Disconnect the fluid lines from the actuator.



Position container to collect fluid loss.



Remove the 2 bolts.



Remove and discard the plastic spacer washers.



Remove and discard the O-ring seals.



Install blanking caps to the exposed ports.

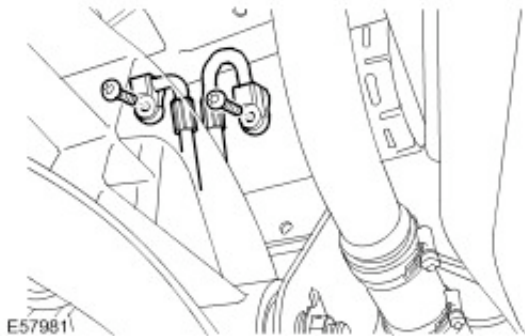

7.  **CAUTION: Use a wrench on the hexagon provided to prevent the ball joint rotating.**

Release both stabilizer bar links.

-  Remove the 2 nuts.

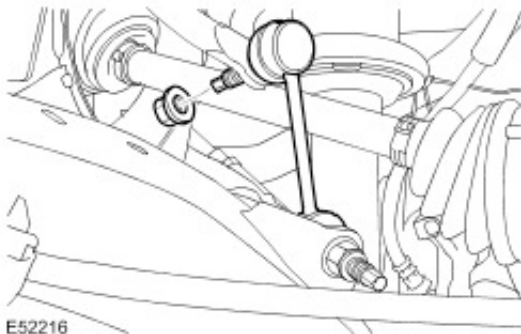

8. Remove the body mount retaining bolts.

-  Remove the 8 bolts.

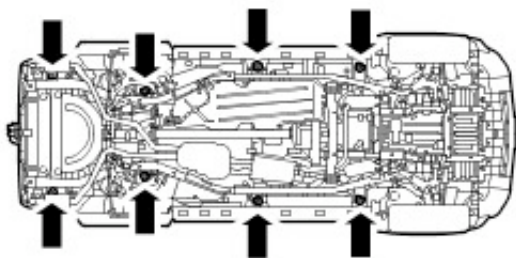

9.  **CAUTION: Only raise the body sufficiently to remove the body mount.**



Raise the body.

-  Using suitable stands, raise the body to release the body mounts.

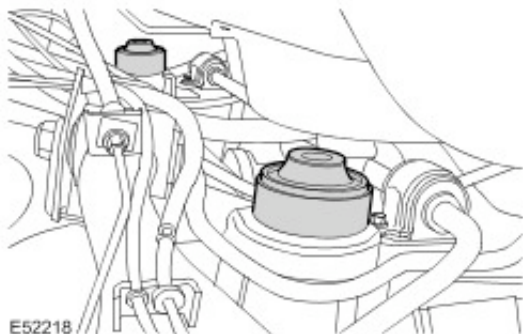
10. Remove the 2 rear body mounts.



11 . Remove the stabilizer bar and actuator assembly bushings.

-  Remove the 4 bolts.
-  Remove the 2 clamps.

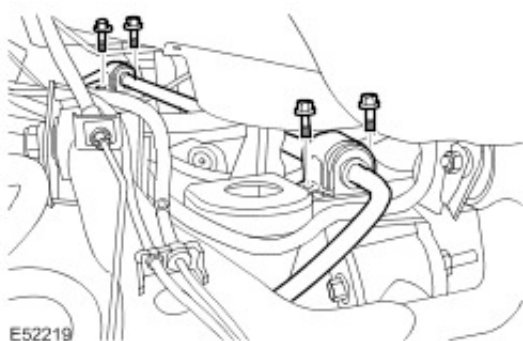

12 . **NOTE:**

Note the fitted position.

With assistance, remove the stabilizer bar and actuator assembly.

Installation

1 .



CAUTION: Make sure the stabilizer bar is correctly installed.

With assistance, install the stabilizer bar and actuator assembly.

2 . Install the stabilizer bar and actuator assembly bushings.

3 . Install the stabilizer bar clamps.

-  Tighten the 4 retaining bolts to 62 Nm (46 lb.ft).

4 .



CAUTION: Use a wrench on the hexagon provided to prevent the ball joint rotating.

Connect the RH stabilizer bar link.

-  Install a new nut and tighten to 115 Nm (85 lb.ft).

-

5



CAUTION: Make sure the actuator fluid lines are not damaged or kinked during removal or installation.







CAUTION: Care must be taken to avoid damage to the plastic spacer washers and O-ring seals during installation of the fluid lines to the actuator.

NOTE:

Some fluid spillage is inevitable during this operation.

Connect the fluid lines to the actuator.

-  Clean the component mating faces.
-  Remove the blanking caps from the ports.
-  Install new plastic spacer washers and O-ring seals.
-  Tighten the 2 bolts to 22 Nm (16 lb.ft).

6 . Bleed the rear of the Dynamic Response system using T4.

7 .



CAUTION: Use a wrench on the hexagon provided to prevent the ball joint rotating.

Connect the LH stabilizer bar link.

-  Install a new nut and tighten to 115 Nm (85 lb.ft).

8 . Install the body mounts.

9 . Lower the body.

-  Remove the stands.

10 . Install the body mount retaining bolts.

-  Tighten the 8 retaining bolts to 133 Nm (98 lb.ft).

11 . Install the wheels and tires.

-  Tighten the wheel nuts to 140 Nm (103 lb.ft).

12 . Lower the vehicle.

13 . Install the spare wheel and tire.

14 . Install the rear bumper cover.

For additional information, refer to [Rear Bumper Cover \(76.22.74\)](#)