

# Ride Height Adjustments (60.90.03)

## Special Service Tools



Gauge, Ride height  
204-557B



**CAUTION:** Make sure the wheels and tires, tie rod ends, suspension joints and wheel bearings are free from damage, wear and free play.



**CAUTION:** Make sure there are no heavy objects in the vehicle.



**CAUTION:** The ride height must be measured with the vehicle weight supported by the suspension.



**CAUTION:** With the engine running and all vehicle doors closed, make sure the air suspension is functioning and the vehicle height can be raised and lowered using the air suspension switch.



**CAUTION:** Drive the vehicle on to a flat, level surface.



**CAUTION:** Make sure the steering is in the straight ahead position.

### NOTE:

This procedure must be carried out after replacement of the air suspension control module or height sensor link arm, removal or replacement of the front or rear upper arms or the height sensor. The ride height does not need calibration after removal or replacement of the front or rear air springs or shock absorbers.

1. Using the Land Rover approved diagnostic system, carry out the ride height adjustments.

2.



**CAUTION: Make sure the vehicle is not moved once it has been positioned to take measurements.**

Position the vehicle on a flat level surface.

3. Connect IDS to the vehicle data link connector.

- Connect the vehicle data link cable into the vehicle communications module.
- Connect the IDS USB Lead into the vehicle communications module.
- Connect the data link cable to the data link connector.
- Connect the IDS USB lead to the IDS USB port.

4.



**CAUTION: Make sure the ignition switch is turned off, the park brake is on and the selector lever is in park.**

**NOTE:**

IDS already loaded with the latest issue of software.

Switch IDS on and navigate to the vehicle identification number (VIN) input screen.

5. Enter the VIN and navigate to the vehicle configuration menu.

- Select setup and configuration.
- Select air suspension height calibration and read all warnings and cautions.

6. **NOTE:**

Do not install the special tool over a locking wheel nut.

**NOTE:**

Make sure the special tool is square to the wheel face with the measuring rod in a vertical position.

**NOTE:**

Take the measurement from the top edge of the slider on the special tool.

**NOTE:**

Make sure the fender splash shields are correctly fitted.

Once in the suspension height measurement screen, use the special tool to measure and record the height setting from each wheel center to the wheel arch.

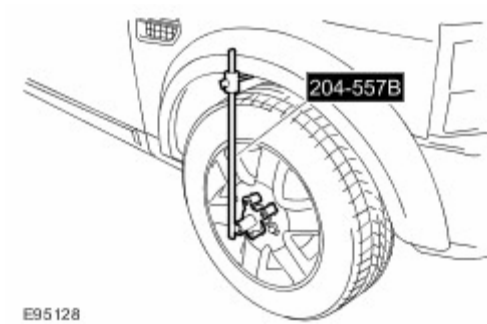

7.



**CAUTION: IDS will now cause the vehicle height to change.**

Input the ride height measurements taken from the vehicle into IDS.

8. Using the special tool, repeat the vehicle ride height measurements.

9. After successful calibration of the air suspension switch off IDS and return to its original position.