



Technical Service Bulletin

No.LTB00097

09 November 2007

This bulletin supersedes TSB LA211-002/2006 dated 24 April, which should either be destroyed or clearly marked to show it is no longer valid (e.g. with a line across the page).

Subject/Concern: Discovery 3/LR3, Range Rover Sport - Minor Steering Column Knock
--

Models:		
Discovery 3 / LR3		VIN-range: 000303-444606
Range Rover Sport (LS)		VIN-range: 900109-122778

Markets: All **Section:** 211-04

Summary:

A customer may report a concern of a minor knocking noise from the front end of the vehicle (steering) when driving over small bumps or undulating/rough road surfaces.

This TSB has been reissued to add the applicability of Range Rover Sport, a change to the affected VIN range for Discovery 3/LR3, a change to the Causal Part number, a change to the Condition Code, a change to the retaining bolt part number, and also to add a Suggested Customer Concern Code.

Cause: Dynamic movement in the lower steering shaft sliding joint due to low sliding loads. **Suggested Customer Concern Code - N58.**

Action: Should a customer express concern regarding the above, refer to the Service Procedure detailed in this bulletin to determine the source of the noise/excess movement.

Parts Required:		
Description	Part Number	Quantity
Upper intermediate shaft	QLB500070	1
Upper to lower intermediate shaft retaining bolt	QYG10016L	1
Lower intermediate shaft universal joint to steering gear retaining bolt	QYG500100	1
Lower intermediate shaft - right-hand	QMN500240	1
Lower intermediate shaft - left-hand	QMN500250	1

Labour Time:		
Operation Description	Operation No.	Time
Renew the intermediate shaft	57.40.22	0.30 hour
Renew the lower shaft (Discovery 3/LR3)	57.40.27	0.90 hour
Renew the lower shaft (Range Rover Sport)	57.40.27	0.90 hour

Repair/Claim Coding:

Causal Part:	QMN500240
--------------	-----------

ACES Condition Code:	33
Defect Code:	

Diagnostic Procedure

The following checks should be completed **before** the steering intermediate shaft is renewed (referring to the relevant Operation Numbers - quoted above - in GTR).

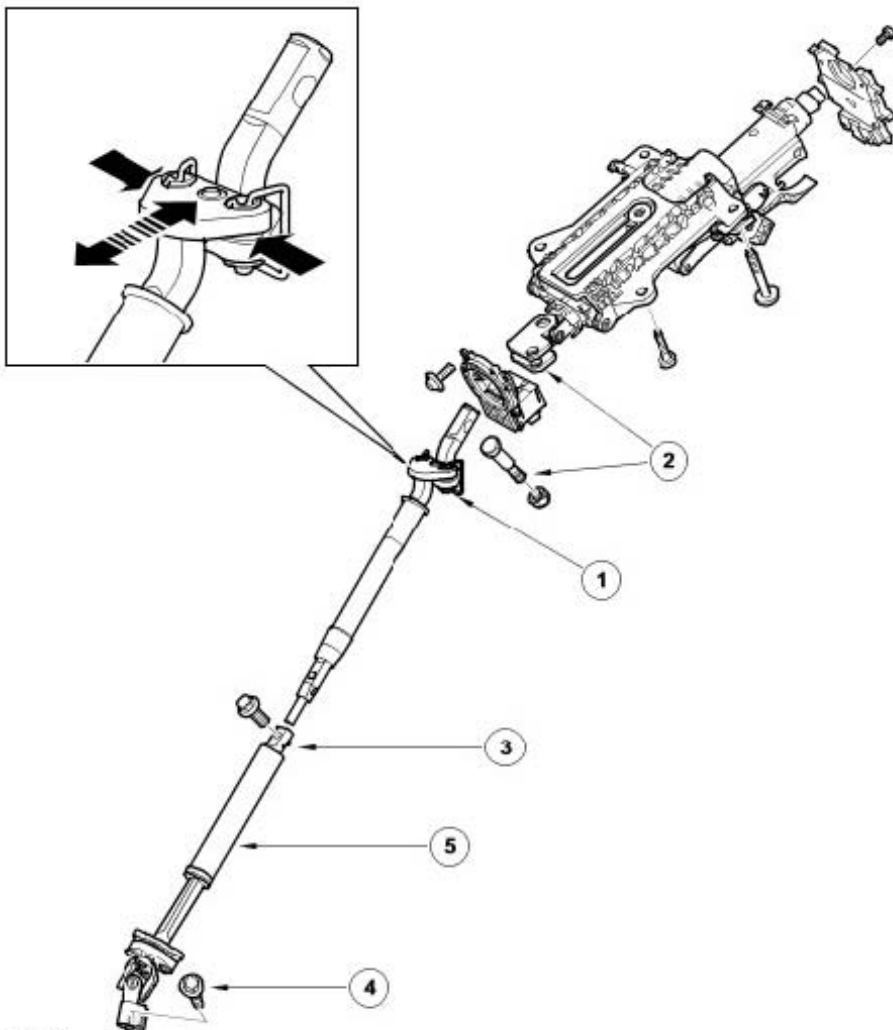

- 1 Examine the steering column intermediate shaft 'decoupler' (item 1 in illustration) integrity, ensuring that the steel and rubber washers are correctly located. 1 . If excessive movement exists at the decoupler or the washers are not correctly located, renew the intermediate shaft.
- 2 Check the steering column universal joint to upper intermediate shaft connection (item 2 in illustration) retaining torque; 30Nm (22lb-ft).
- 3 Check for movement at the intermediate to lower shaft joint (item 3 in illustration). 1 If movement exists, renew the bolt and tighten to 30Nm (22lb-ft).
- 4 .
4 Check for movement at the lower shaft universal joint to steering gear connection (item 4 in illustration). 1 If movement exists, renew the retaining bolt and tighten to 30Nm (22lb-ft).
- 5 . Check for movement at the lower shaft sliding joint (item 5 in illustration).
1 If movement exists, renew the lower shaft.