

PUBLISHED: 11-MAY-2011

2007.0 RANGE ROVER SPORT (LS), 303-05

ACCESSORY DRIVE - TDV6 2.7L DIESEL

DESCRIPTION AND OPERATION

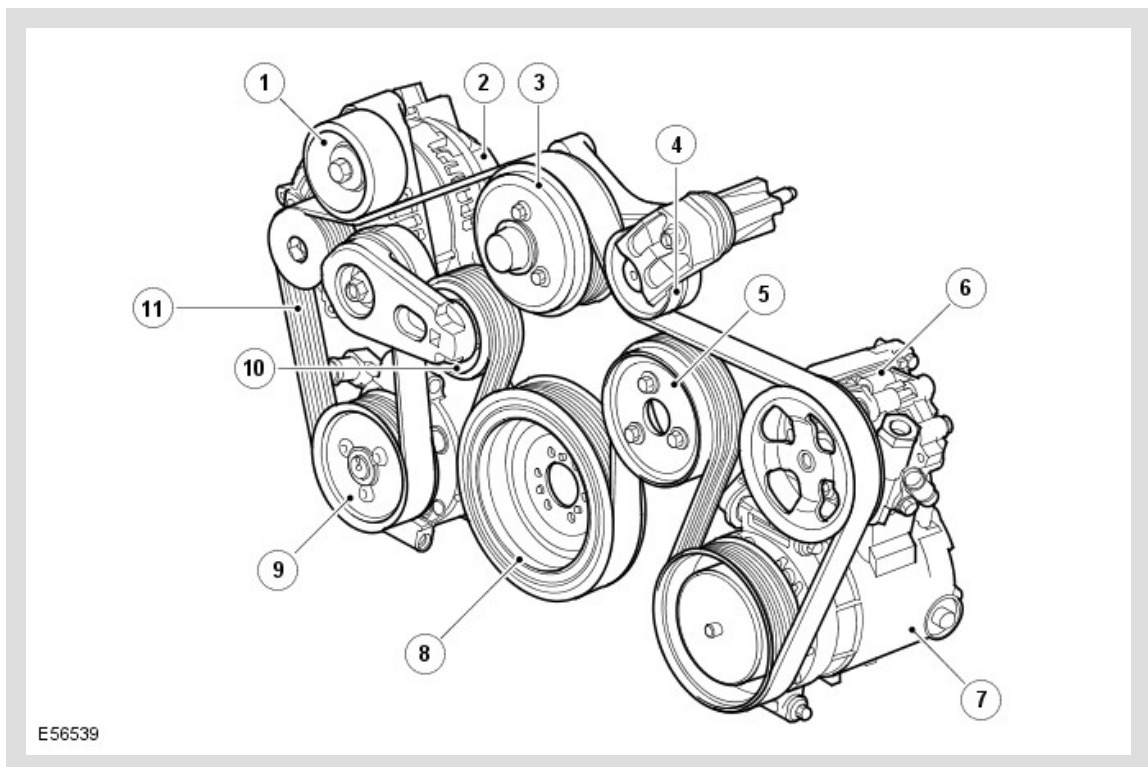

ITEM	DESCRIPTION
1	Idler assembly
2	Generator
3	Engine cooling fan
4	Tensioner assembly
5	Engine coolant pump
6	Power steering pump
7	A/C compressor
8	Torsional vibration damper

9	Dynamic Response pump (if fitted)
10	Tensioner assembly
11	Accessory drive belt

GENERAL

The engine crankshaft pulley drives the accessory components, which comprise the torsional vibration damper, generator, power steering pump, A/C compressor, Dynamic Response pump and coolant pump, via the accessory drive belt.

The belt, which is a maintenance free poly-V type belt, is automatically pre-loaded by the tensioning rollers and routed over deflection pulleys in order to maintain sufficient adhesion about the drive wheels. This ensures slip-free drive of the accessory components.