



Technical Service Bulletin

No.LS204-001v3
22 September 2005

Reissue

Please replace the previous edition of this bulletin.

This bulletin supersedes TSB LS204-001v2/2005 dated 22 August, which should either be destroyed or clearly marked to show it is no longer valid (e.g. with a line across the page).

Subject/Concern: Range Rover Sport - 20 Inch Wheel Installation
--

Models:	
Range Rover Sport (LS)	VIN-range: 5A900505-6A917472

Markets: All **Section:** 204-04

Summary:

20 inch wheels installed to a vehicle not originally built with this wheel size, may lead to customer concern of steering shimmy and steering 'pull' under heavy braking.

This bulletin has been re-issued to correct the closing VIN.

Cause: 20 inch road wheels can only be installed to vehicles which have a damped steering gear. Some **non-supercharged** vehicles do not have a damped steering gear.

Action: Should a customer request a 20 inch wheel installation, refer to the Service Information detailed in this bulletin.

Service Information

NOTE: 20 inch wheels must only be installed to vehicles with a damped steering gear.

Range Rover Sport has been manufactured with two types of steering gear, **damped** and **non-damped**.

Vehicles manufactured with 20 inch wheels are built with a damped steering gear.

Vehicles manufactured with 17, 18 and 19 inch wheels may have either a damped **or** non-damped steering gear.

If 20 inch wheels are to be installed to a vehicle not manufactured with 20 inch wheels, the vehicle must be examined to determine if it has a damped steering gear.

- 1 . The illustration shows A, a non-damped steering gear and B, a damped steering gear.
- 2 . The steering gear can be inspected from the wheelarch area to determine its type.

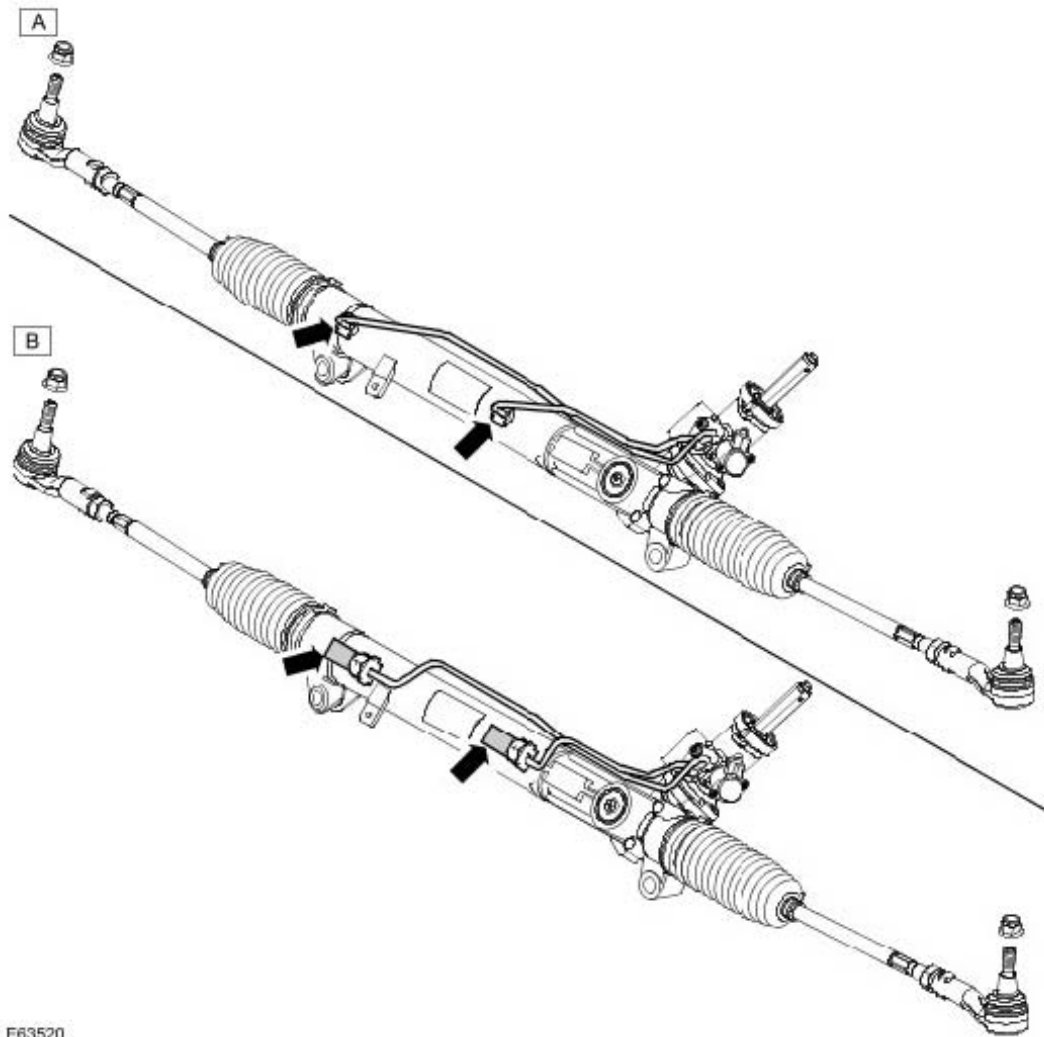

E63520

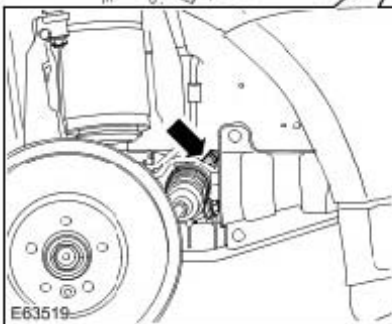
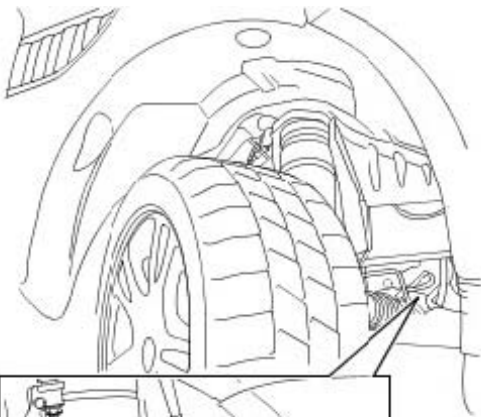

E63519